

RADARPILOT platinum

NACOS Platinum Series

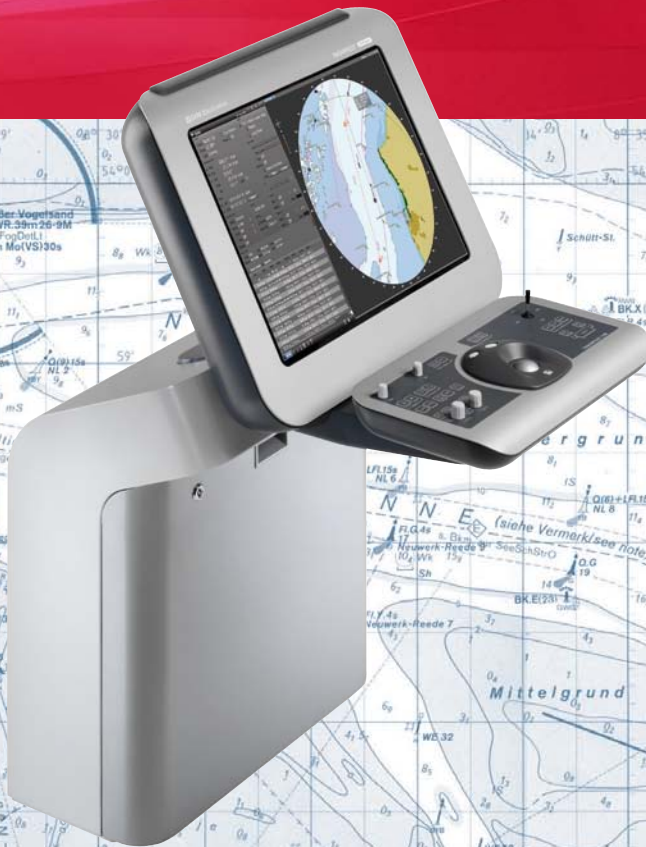

The First IP-Radar

Wärtsilä SAM Electronics

RADARPILOT platinum

NACOS Platinum Series

The Captain's First Choice

Ships are larger, traffic denser and time for important decision making even less. Thus, information management is the No.1 issue for 21st century navigation. Wärtsilä SAM Electronics new Platinum series radar provides the navigator with the right information for the right decision at the right time.

Designed to exceed customer needs, the innovative and ergonomic design provides unprecedented levels of user friendliness and safe operation for experts and novices alike. When it comes to radar, the **RADARPILOT Platinum** is the captain's first choice.

Radar display

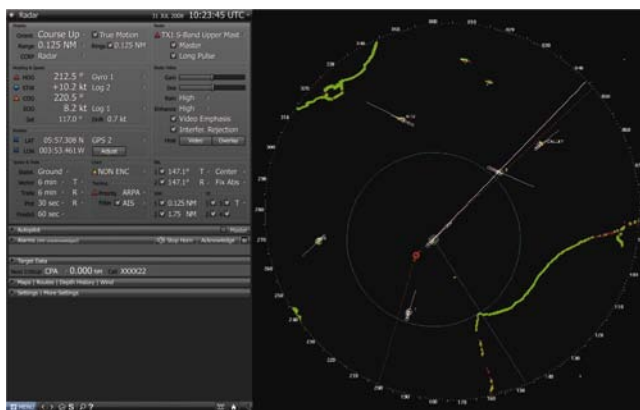

Conning display



Functional Package "Radar"

- IP Radar
- High resolution wide screen displays
- Built-in radar interswitch
- Tracking of up to 40 Radar and 200 AIS targets
- Automatic clutter suppression
- Enhanced small target detection
- Built-in performance monitor
- Multi-layer display of user chart and track data
- 5 different brightness settings for day and night
- Favourite user settings
- Man overboard button
- S-Mode
- Type approved as MKD for AIS R5 Supreme
- Integrated VDR display and operation of VDR 4360
- Easy to operate either by trackball or functional radar keyboard
- On-screen NAVTEX updates
- Integrated conning page
- Output for conning display
- Online operators manual and user help function

Functional Package "Advanced Radar"

Upgrade your RADARPILOT with additional functionality via a simple software licence. A fast trouble-free procedure adapts your radar to specific needs, including a conning display and other highly advanced features.

- All "Radar" features
- Tides and current display
- Remote maintenance function
- Radar Video Merging
- High Speed Radar (for high speed crafts)



Functional Package "Chartradar"

Upgrade to Chartradar and benefit from all the advantages of the advanced radar package and more. Via an easy-to-use licence key, the radar becomes Chartradar according to IMO standards. The combination of radar video superimposition and ECDIS provides significant increases in situational awareness!

- All "Radar" features
- Chart data bases: ENC S57/S63; Admiralty AVCS; C-Map ENC and CM93-3
- Chart maintenance based on RTU and dynamic licensing
- Approved as ECDIS-Backup
- Chart information

User Centred Design

The Human Machine Interface (HMI) of the NACOS Platinum series is a story in itself. Understanding the need for easy and safe operation across systems and applications, Wärtsilä SAM Electronics has pooled its 30 years of experience with that of leading international human factors expertise. Working together throughout an ambitious User Centred Design process, the result is an HMI that is intuitive, transparent and consistent. The HMI supports both novices and expert users, and is designed to match the user's information needs. By following operating principles similar to those of modern browsers and major software packages, the NACOS Platinum HMI will be immediately familiar to any computer user, and the easy overview and simplicity of operation directly allows the user to concentrate on the task of navigating the ship safely.

IP Radar

RADARPILOT Platinum is completely LAN based, offering scalability and flexibility to new levels never seen before. With such adaptability, Platinum series radars offer tailor made solutions for all ship types as well as great potential for future system upgrades and extensions.

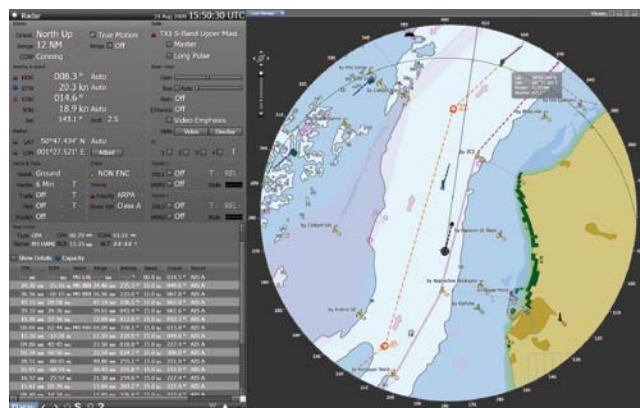

Chartradar display

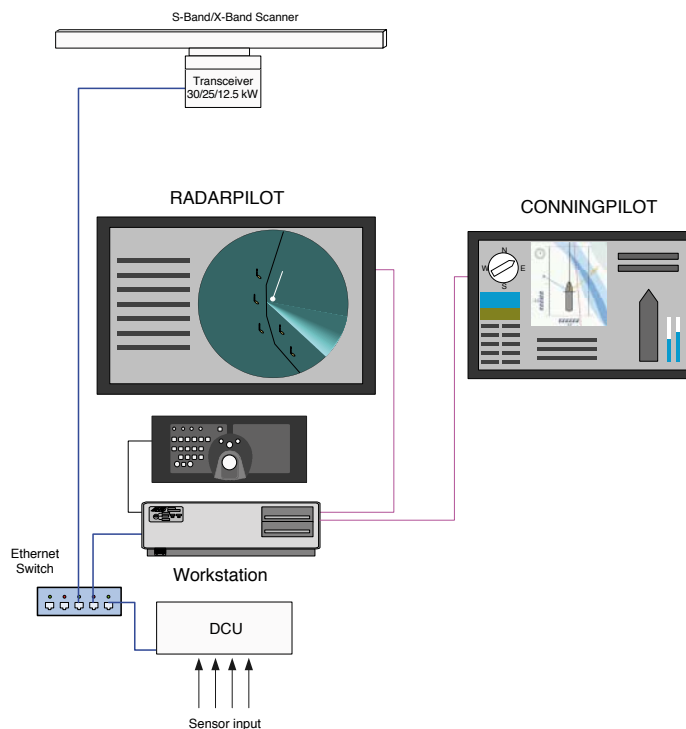

Installation RADARPILOT with conning

Benefits of NACOS Platinum Series

- Easy to install and to maintain
- Cost efficient solution focused on increasing user value
- Extremely user friendly = less training
- Common hardware platform = reduced spare parts

RADARPILOT platinum

Technical Data

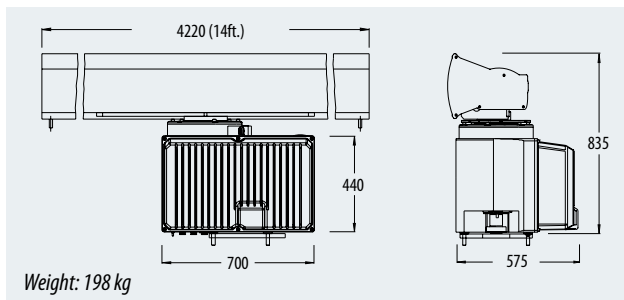

S-Band Antenna Unit with integrated performance monitor and 30 kW S-Band transceiver, optional 30kW bulkhead transceiver

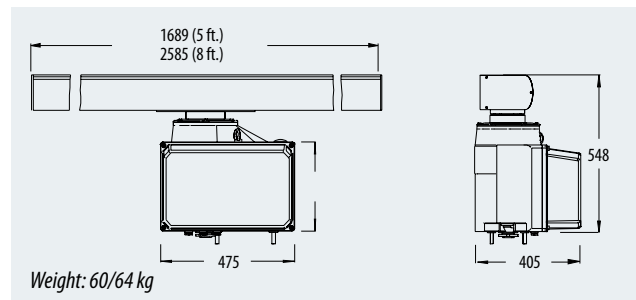

X-Band Antenna Unit with integrated performance monitor and 12.5 or 25 kW X-Band transceiver, optional 25 kW bulkhead transceiver

AC voltage* frequency	1 x 115 V 60 Hz	1 x 230 V 50/60 Hz	3 x 230 V 50/60 Hz	3 x 400 V 50/60 Hz	3 x 450 V 60 Hz	Power Cons. X-Band [VA]	Power Cons. S-Band [VA]
X/S-Band antenna unit		x	x	x	x	250	1300
X/S-Band bulkhead transceiver	x	x				150	150

*Tolerances according to IEC 60945

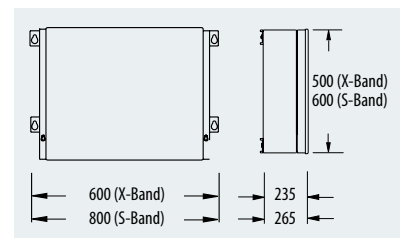

Bulkhead Transceiver (X-Band / S-Band)

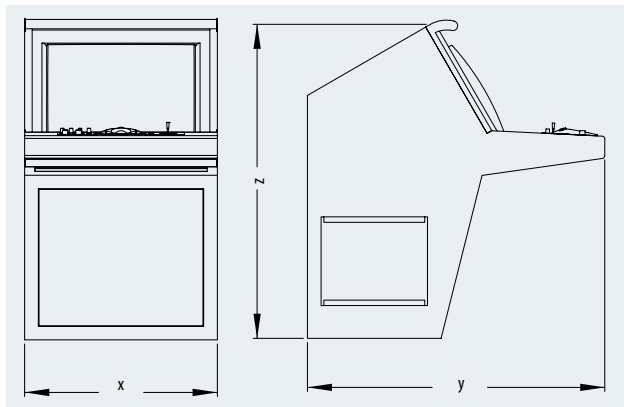

C4 Console unit with integrated control panel and display electronics

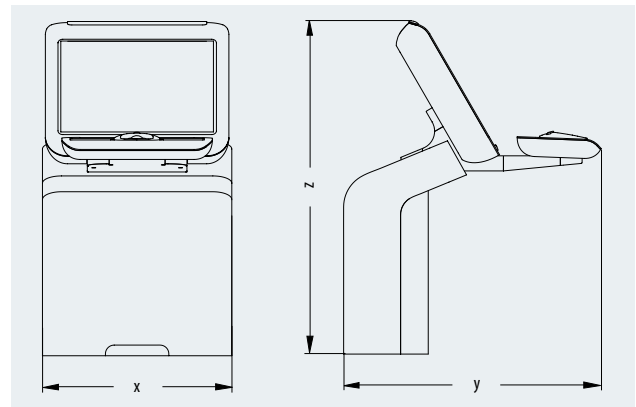

C5 Console unit with integrated control panel and display electronics

RADARPILOT Platinum basic versions

		Dimensions [mm]								
Characteristics		C4 Console unit			C5 Console unit			Console monitor		
Category	Size	x	y	z	x	y	z	x	y	z
CAT2	22" TFT	600	1090	1150	600	887	1168	566	107	388
CAT1	26" TFT	700	1090	1150	700	895	1168	642	133	436

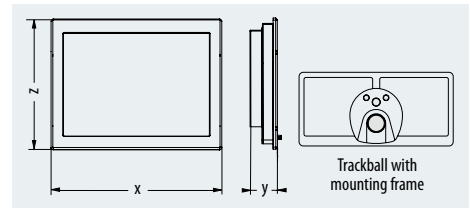

Console monitor flush mounted

Alterations due to technical progress possible. Detailed technical information is available from:

Wärtsilä SAM Electronics GmbH
Automation, Navigation, Communication
Behringstrasse 120
22763 Hamburg · Germany

Phone: +49 (0)40 - 88 25 - 28 41
Fax: +49 (0)40 - 88 25 - 41 16
ANC@sam-electronics.de
www.sam-electronics.de