

SAM 4642

Dual Axis EM-Speed Log



SAM 4642

General

System Summary

SAM 4642 is a navigation 2 axis electromagnetic speed log for measuring longitudinal and transverse speed through water. A mile counter and a water temperature sensor is included. Speed information can be relayed to a radar, AIS, VDR and all other relevant devices via NMEA-format connections. Interfaces between the operator unit, electronic unit and sensor comply with IEC 61162 specifications. All relevant IMO requirements are met or exceeded.

Transducer and Transceiver

SAM 4642 sensor is connected to the electronic unit located within 40 m of the sensor. The connection from the sensor to the electronic unit is via a serial RS-422 data link as well as the connection from the electronic unit to the operator unit. The link between electronic unit and operator unit may be up to 300 m. Power supply is via 230 VAC/115 VAC or 24 VDC. The power consumption is approximately 100 Watts.

Operator Unit

The display is optimized for the intended purpose and consists of several numerical and alphanumeric LED segment displays. For user inputs six keys are available. For audible warnings the operator unit is equipped with a buzzer. The communication between operator unit and sensor is established as a bi-directional exchange of proprietary and standard NMEA telegrams via the Com-NMEA interface. The system can be calibrated from the operator unit. Optionally, Windows software for calibration via a laptop is available. The operator unit is normally console mounting. The dimension is international standard of 144 x 144 mm. A ruggedised housing for desktop mounting is also available. Operator unit power supply is 24 V DC. Power consumption is approximately 10 Watts.

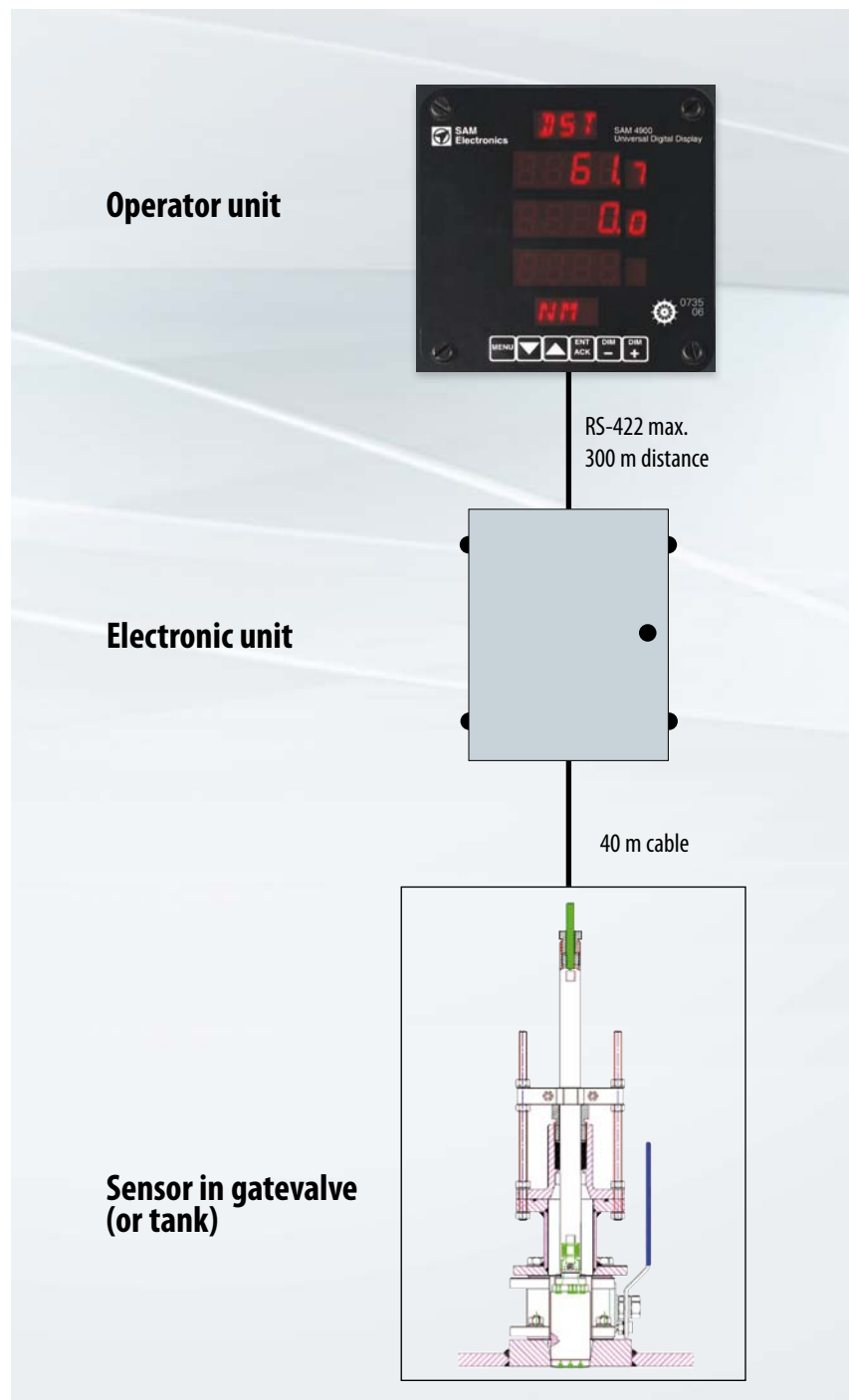

Standard Functions

Distance mode

Total counter

Trip counter



Speed through water mode

Trabsversal speed

Longitudinal speed



SAM 4642

Technical Data

Power supply	230 VAC (50/60 Hz), 24 VAC (50/60 Hz), 24 VDC
Power consumption	Max 100 W
Speed range	± 40 kts in both axis
Water track	Less than 3 m below sensor
Accuracy	Complies with IEC 61023 / 0,2 Kn or 2 % whichever is greater
Outputs	- 2 x NMEA 0183 / RS 422 - alarm relay output
Sensor installation	Tank or gate valve

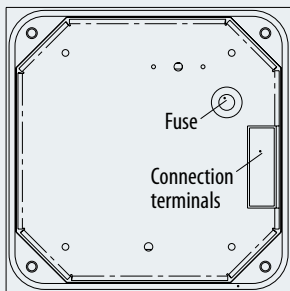

Display unit backside

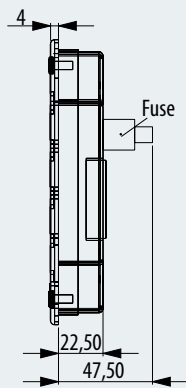

Lateral view

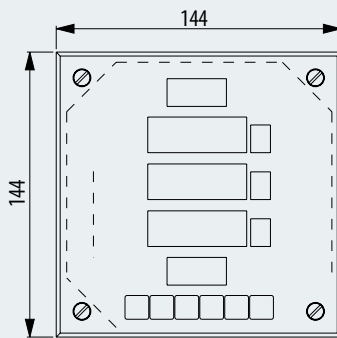

Display unit frontside

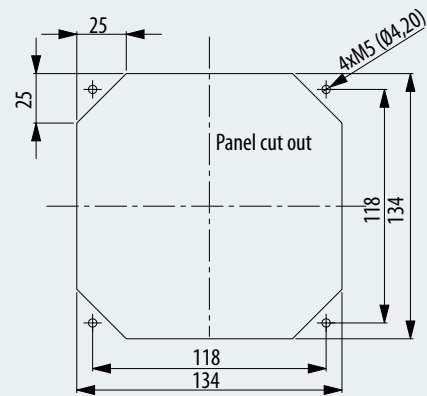

Display panel cut out

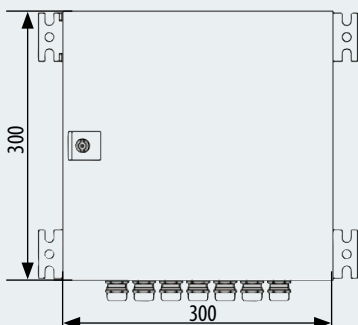

Electronic unit

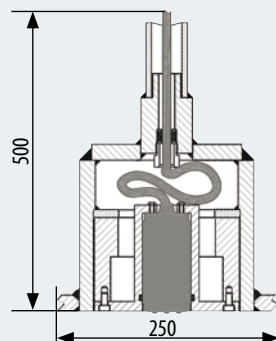

Tank installation

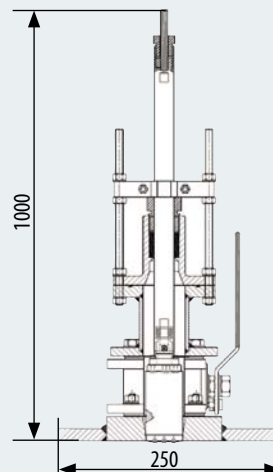

SB gate valve

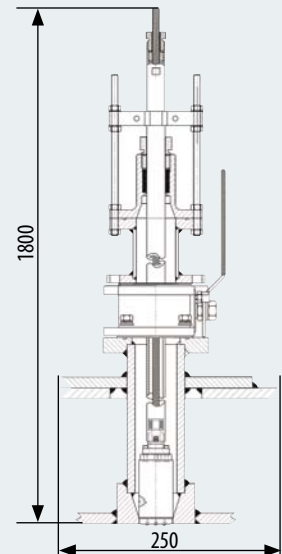

DB gate valve

Wärtsilä SAM Electronics GmbH
Automation, Navigation, Communication
Behringstrasse 120
22763 Hamburg · Germany

Phone: +49 (0)40 - 88 25 - 28 41
Fax +49 (0)40 - 88 25 - 41 16
ANC@sam-electronics.de
www.sam-electronics.de